

Height of end of the conveyor

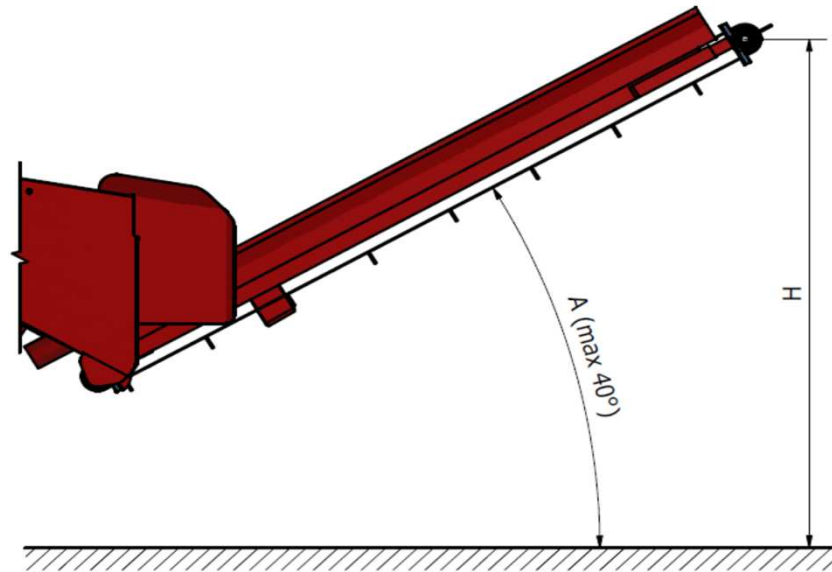

| type of branch logger | type of conveyor | H [cm] | |
|-----------------------|--|---------|---------|
| | | A = 30° | A = 40° |
| TR70 | 2,1 m to side - driven by a hydraulic motor with rotation speed control | 196 | 226 |
| | 2,6 m to side - driven by a hydraulic motor with rotation speed control | 221 | 258 |
| | 2,6 m backwards - driven by a hydraulic motor with rotation speed control | 225 | 262 |
| | folding conveyor 3,4 backwards - driven by a hydraulic motor with rotation speed control | 262 | 310 |
| TR75 | 2,1 m to side - belt driven | 183 | 213 |
| | 2,6 m to side - belt driven | 208 | 245 |
| | turnable conveyor 2,6 m - driven by a hydraulic motor with rotation speed control | 199 | 236 |
| | folding conveyor 3,4 m to side - belt driven | 245 | 293 |
| | turnable folding conveyor 3,4 m - driven by a hydraulic motor with rotation speed control | 236 | 284 |
| TR110 | 2,6 m to side - belt driven | 200 | 237 |
| | 2,6 m backwards - driven by a hydraulic motor with rotation speed control | 200 | 237 |
| | folding conveyor 4,1 m to side - belt driven | 275 | 333 |
| | folding conveyor 4,1 m backwards - driven by a hydraulic motor with rotation speed control | 275 | 333 |
| EM70, SM70 | 2,1 m - belt driven | 175 | 205 |
| | 2,6 m - belt driven | 200 | 237 |
| | folding conveyor 3,4 m - belt driven | 237 | 285 |
| SMV70, SMH70 | 2,1 m - belt driven | 181 | 211 |
| | 2,6 m - belt driven | 206 | 243 |
| | folding conveyor 3,4 m - belt driven | 243 | 291 |
| EM110 | 2,6 m - belt driven | 199 | 236 |
| | folding conveyor 4,1 m - belt driven | 274 | 332 |
| SMH110, SMV110 | 2,6 m - belt driven | 215 | 252 |
| | folding conveyor 4,1 m - belt driven | 290 | 348 |